

COCCO 50

THE TRANSPORTER

COCCO 50

THE TRANSPORTER



BG LIFT srl
Via Lionello Fiumi, 22
37010 Cavaion Veronese (VR) Italy
Phone: +39 045 8240360
E-mail: info@bglift.com
www.bglift.com



DB0015_0-ITA/ENG_REV/00



COCCO 50

Portata utile: 40.000 kg
Payload capacity: 40.000 kg

COCCO 50

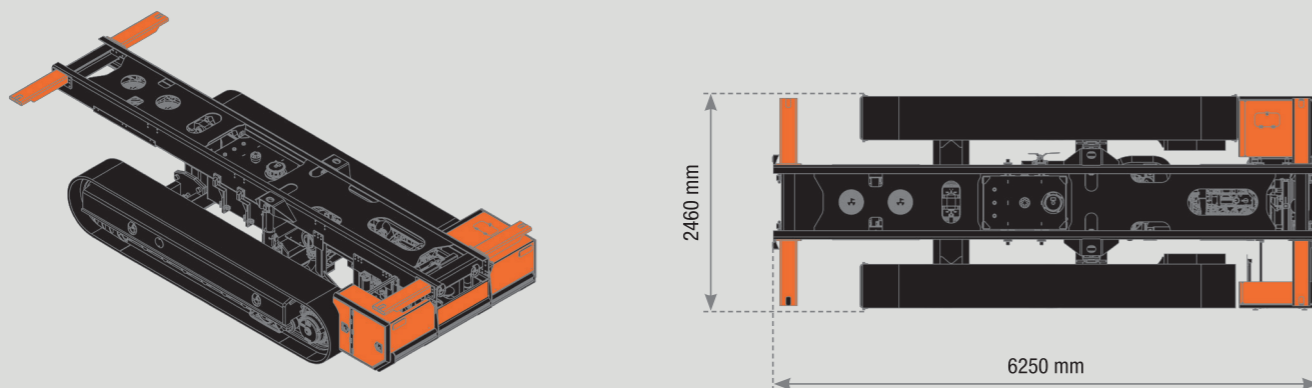
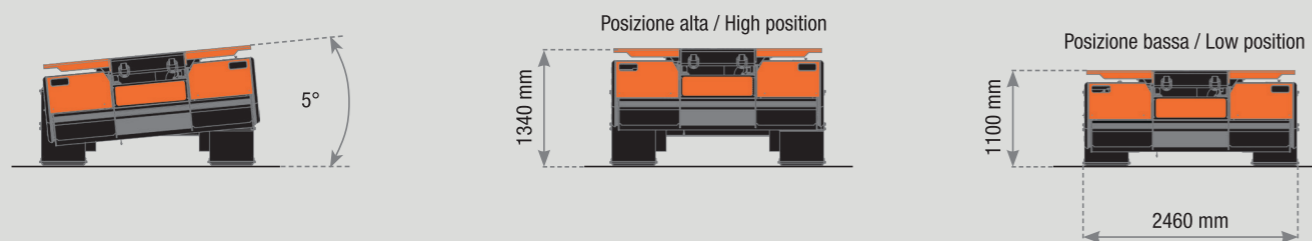
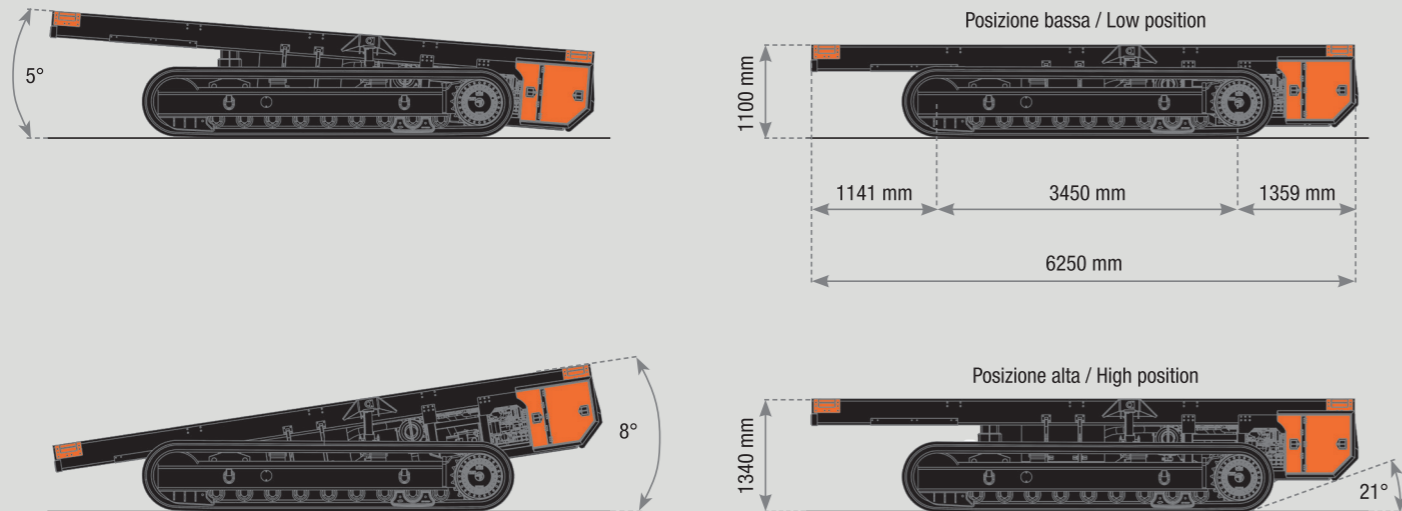

Caratteristiche principali Main Features

Lunghezza / Length	6250 mm	Peso a pieno carico / Full load weight	50000 kg
Larghezza / Width	2460 mm	Portata utile / Payload capacity	40000 kg
Altezza minima / Min Height	1100 mm	Motore termico / Combustion Engine	DEUTZ TCD 3.6 - Stage V
Altezza massima / Max Height	1340 mm	Potenza massima / Max power	105 kW - 141 Hp
Livellamento longitudinale Longitudinal levelling	8° / 5°	Capacità serbatoio diesel Diesel tank capacity	180 l
Livellamento laterale / Lateral levelling	5°	Capacità serbatoio olio / Oil tank capacity	300 l
Pendenza superabile / Gradeability	35%	Trasmissione / Transmission	Idrostatica / Hydrostatic
Pendenza laterale massima Max side slope	18%	Pressione / Pressure	350 bar
Velocità massima / Maximum speed	2,4 km/h	Impianto idraulico Hydraulic system	Pompa idraulica a portata variabile Variable flow hydraulic pump
Peso a vuoto / Empty weight	10000 kg	Radio comando / Radio remote control	Scanreco Can Bus

COCCO. Il primo transporter di BG Lift

Progettato per superare i limiti, **COCCO** è il transporter che continua la corsa dove gli altri si fermano. La sua straordinaria versatilità lo rende uno strumento indispensabile: può trasportare carichi di ogni tipo con estrema facilità. Una sola macchina, infinite possibilità.

COCCO. The first BG Lift transporter

Designed to push beyond limits, **COCCO** is the transporter that keeps going where others stop. Its extraordinary versatility makes it an indispensable tool: it can carry all kinds of loads with ease. One machine, endless possibilities.